

# Microblasting Equipment

## PEENMATIC 1100 ZI / ZID



### Standard equipment:

- Front flap door which is operated with cylinders actuated by compressed gas, with arm supports for a comfortable working. With integrated sight window, provided with a safety glass and an attrition-proof glass in a quick change frame
- Side feeding doors, width 410 mm x height 220 mm or width 410 mm x height 320 mm (special), on the left and on the right side of the equipment, with double lamellar curtain
- Door interruption switch
- Working grate made of perforated plate, two-piece, detachable, diameter of holes 5 mm
- Padded sleeves and gloves, exchangeable
- Microblasting pistol unit, type EF 3, with hard metal blasting nozzle HSD 5/10, adjustable via pressure reducing valve, 0 - 8,5 bar, microblasting pressure reading on the manometer
- Microblasting agent pre-accelerating system with moving injector, adjustable via pressure reduction valve, 0 - 4 bar, pressure reading on the manometer
- Automatic, selective recycling of microblasting agent by high-performance cyclone
- Built-in high surface micro filter system, containing two filter cartridges with 2 m<sup>2</sup> filter surface each. Automatic, pneumatic filter cleaning with time intervals
- Dust collector, made of steel, complete with packing
- Ventilator for high surface micro filter system, electronically continuously variable
- Blow-out pistol (air-blasting pistol)
- Foot actuated switch with impulse contact
- Compressed-air connection at equipment 1/2" G, including oil and water separator
- Control panel with all necessary switches and control elements
- Key-operated switch, on / off, with 2 keys
- Illumination, 3 x 18 Watt

### Optional accessories:

(on request)

- Rotary table unit, made of aluminium or steel, Ø 800 mm, manually rotatable or electronically continuously variable
- Drying system for microblasting agents, electronically continuously variable
- Fitting out of both side feeding doors, left and right, with feeding boxes and integrated rubber lined connecting passages, for the cleaning of screws
- Second microblasting pistol unit, pneumatically controlled, with hard metal blasting nozzle HSD 5/10 or HSD 8/15
- Hour counter of microblasting time

#### Sales / Development

iepcO ag  
Hofstrasse 21  
CH-8181 Höri  
Phone +41 / (0)44 861 16 16  
Fax +41 / (0)44 860 63 86  
www.iepcO.ch

#### Production Plant

iepcO ag  
Steiächerweg 10  
CH-5316 Leuggern  
Phone +41 / (0)56 268 80 40  
Fax +41 / (0)56 268 80 50  
info@iepcO.ch

Technologies for  
perfect surfaces

# Microblasting Equipment

## PEENMATIC 1100 ZI / ZID

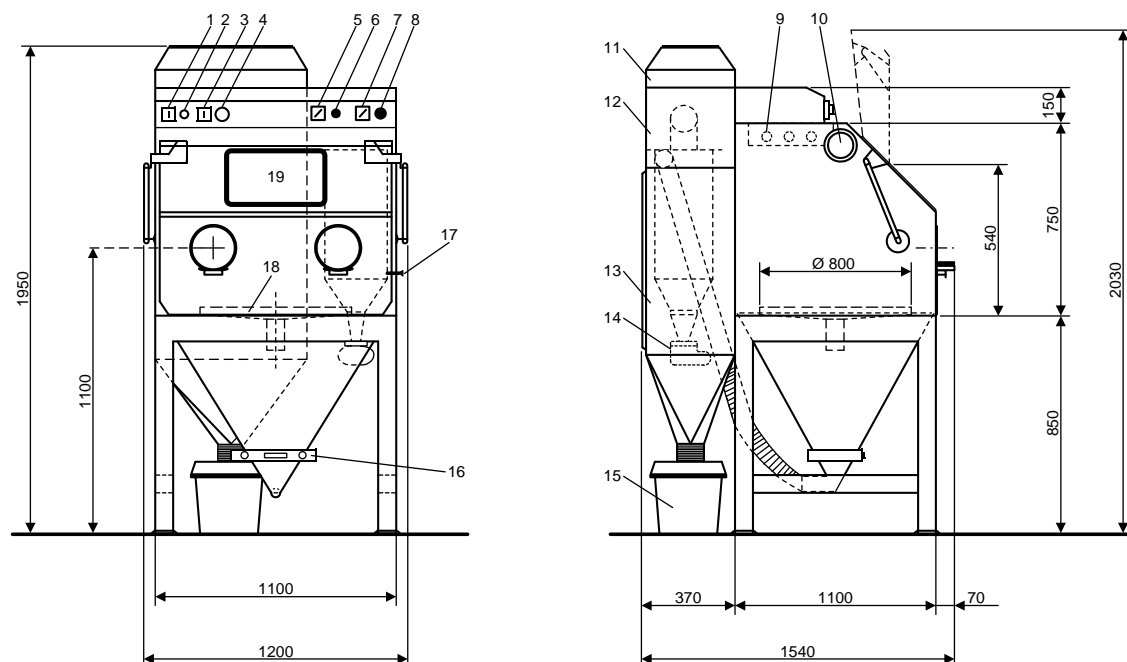

### Legend:

- |   |  |
|---|--|
| 1 Key-operated switch   | 9 Illumination, 3 x 18 Watt            |
| 2 Control safety  | 10 Adjustable air inlet filter caps    |
| 3 Selector switch microblasting pistol left or microblasting pistol right | 11 Ventilator                          |
| 4 Potentiometer drying system for microblasting agents                    | 12 Filter cleaning                     |
| 5 Manometer for microblasting pistol(s)                                   | 13 Filter                              |
| 6 Pressure regulator for microblasting pistol(s)                          | 14 Moving injector                     |
| 7 Manometer for moving injector   | 15 Dust collector                      |
| 8 Pressure regulator for moving injector                                  | 16 Impurity collecting drawer, 1. step |
| ( Pos. 3, pos. 4 and pos. 18 only on request as an optional accessory )   | 17 Impurity collecting drawer, 2. step |
|   | 18 Rotary table, Ø 800 mm              |
|   | 19 Safety and attrition glass          |

### Usable space:

Width 1'080 x depth 1'080 x height 540 mm.  
Optimal for the surface treatment of workpieces with the dimension of width 850 x depth 850 x height 300 mm

### Operating voltage:

230 V + PE / 50/60 Hz

### Power consumption:

460 W

### Control safety:

3,0 A

### Compressed air connection:

On the side of the building 3/4" G  
On the side of the equipment 1/2" G  
Pressure max. 10 bar

### Sound level:

72 dB(A) without microblasting  
75 dB(A) with microblasting with 3 bar

### Weight:

510 kg

All data are given without liability on our part. We reserve the right to modify constructional design at any time.

### Sales / Development

iepcO ag  
Hofstrasse 21  
CH-8181 Höri  
Phone +41 / (0)44 861 16 16  
Fax +41 / (0)44 860 63 86  
www.iepcO.ch

### Production Plant

iepcO ag  
Steiächerweg 10  
CH-5316 Leuggern  
Phone +41 / (0)56 268 80 40  
Fax +41 / (0)56 268 80 50  
info@iepcO.ch